

SPECIFICATION

A: MATERIAL:

- 1.BODY: NYLON 66
- 2.TERMINAL: Cu PLATED Sn

B: CHARACTERISTICS:

- 1.RATING: 15A 250V~(C-ULus)
10A 250V~(ENEC & CCC & KC)
- 2.INSULATION RESISTANCE:100MΩ MIN,AT 500VDC
- 3.ELECTRIC STRENGTH : 3000 VAC/1MIN,LEAKAGE CURRENT UNDER 0.5mA

C: APPROVALS: C-ULus, ENEC & CCC & KC

- D: MATERIAL USED MUST BE COMPLY WITH HQI-0010
- E: CAN MEET ROHS,ROHS2.0,HF

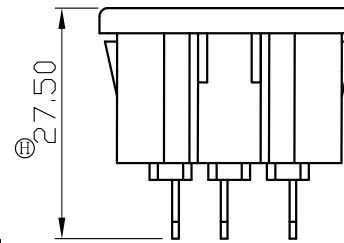
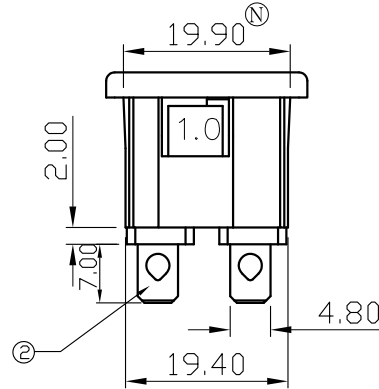
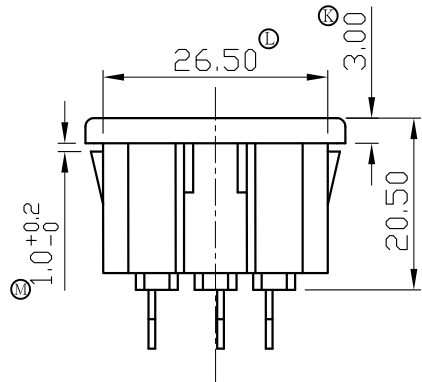
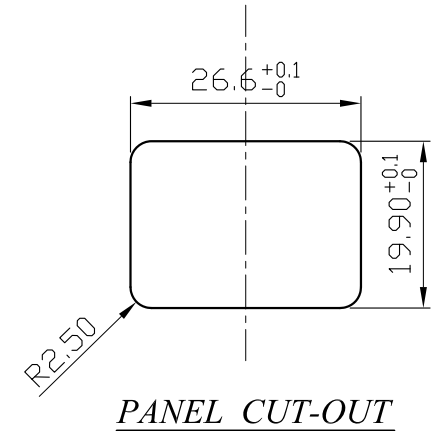
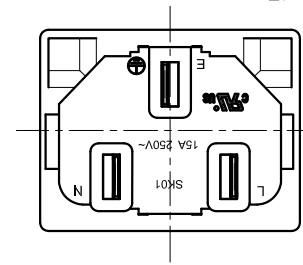
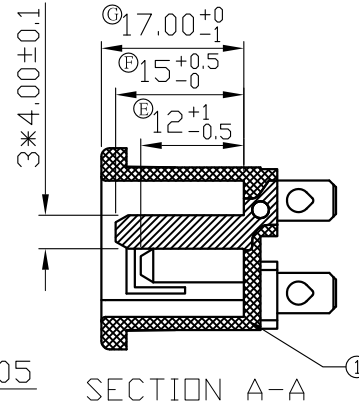
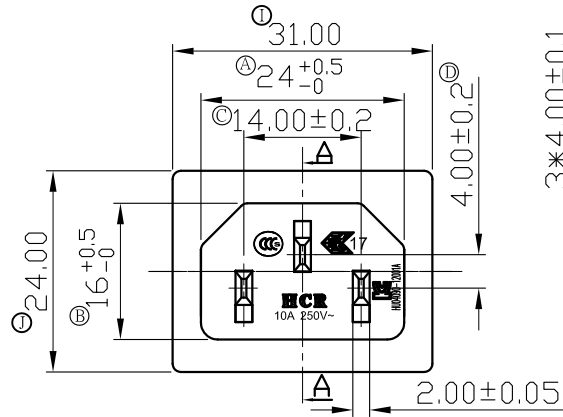

TOLERANCES UNLESS OTHERWISE 未指定容許差尺寸之公差	
BASIC DIMENSIONS TOLERANCES	
UP TO 10 (10以下)	±0.15
ABOVE 10 TO 30(10~30)	±0.3
ABOVE 30 TO 100(30~100)	±0.5
ANGULAR DIMENSIONS(角度)	±5°
DIMENSION UNIT	mm

東莞市華之力電子有限公司 DONGGUAN HCR ELECTRONICS CO., LTD.

2					核准 APPROVED BY	日期 DATE	20120705	投影法 PROJECT		機型 PART NAME	INLET SOCKET
1					校對 CHECKED BY	日期 DATE	20120705	比例 SCALE	1:1	型號 PART NO	SK01
0	2012/09/25	1.新制訂	A0		繪圖 DRAWN BY	日期 DATE	20120705	路徑 DWG NO	E:\成品圖 SK01\800071	料號 ITEM NO	SK01-2801051021H
NO	DATE	REVISION DESCRIPTION	REVISION	DRAWN	APPROVED						